

FRENCH FITNESS

FF-FSR100-CB

FRENCH FITNESS FSR100 COMMERCIAL FUNCTIONAL SMITH RACK, COUNTER BALANCED (NEW)

ASSEMBLY MANUAL

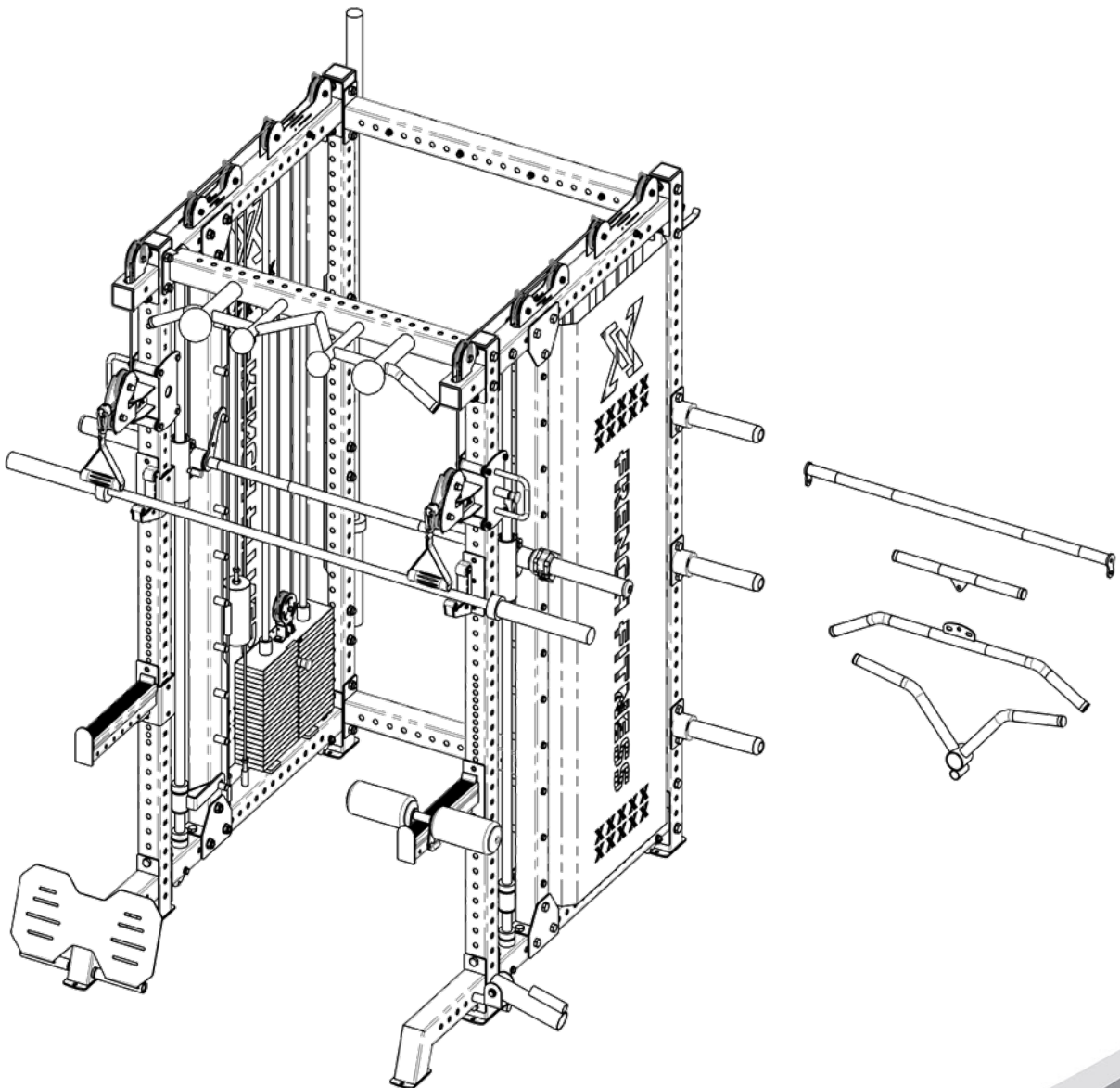

FEATURES

THE ULTIMATE ALL-IN-ONE MACHINE

- Smith Machine (Counterbalanced)
- Squat Rack
- Functional Trainer
- Landmine
- Pull Up Bar
- Seated Row Foot Rest
- Jammer Arm (Optional)
- Leg Press (Optional)
- Bench (Optional)
- Lat Pulldown / Low Row (Optional)
- Dip Handle (Optional)
- Lat Pull Down Seat (optional)
- Pull Up Connecting Bar (optional)
- California Residents see Prop 65 WARNINGS

TECH SPECS

- 11 Gauge Steel
 - Square Tube: 75mm x 75mm x 3mm
 - Size of Ea. Cable Column Hole: 0.658"
 - Maximum user weight: 350 lbs (771 kg)
 - Maximum user weight (Lat Pulldown Knee Cushion): 350 lbs (771 kg)
 - Maximum Capacity (Pull Up Bar): 551 lbs (250 kg)
 - Max Load (J Hooks): 992 lbs (450 kg)
 - Max Load (Spotter Arms): 1102 lbs (500 kg)
 - Max Load (Smith Bar): 992 lbs (450 kg)
 - Max Load (Seated Foot Rest): 661 lbs (300 kg)
 - Max Load (Plate Storage): 135 lbs (Per Weight Horn) x 6 Weight Horns = 810 lbs total
 - Smith Bearing Type: Ball Bearings
 - Weight Stack: (2) 220lb stacks (440lbs total) - Upgraded Weight Stacks Optional
- Note: The machine must be upgraded at the time of purchase since the upgrade is not possible once it ships because the entire stack is different.**
- Pulley to Weight Ratio: 2:1 (Feels like 110 lbs per side due to ratio)
 - Weight: 1197 lbs (543 KG)
 - Ratio: 2:1
 - Inner Frame Width: 42.52"
 - Height to top pulley: 91.2"
 - Height to bar rack: 81.1"
 - Width from weight-horn to weight-horn: 70.9"
 - Inner Frame Width: 42"
 - Width with bar: 86.6"
 - Length: 66.4"
 - Dimensions: 66.4"L x 86.6"W x 91.2"H (L:1689mm, W:220mm, H:2318mm)
 - (2) Olympic Bar Holders (For Storage): Located on Back of Machine

ACCESSORIES INCLUDED

- (1) 7' (86") Olympic Bar
- (2) Dual Hook Revolving Straight Bar
- (3) Lat Pulldown Bar
- (4) Small Straight Bar
- (5) Lat Pulldown Support Pad
- (6) Safety Support / Bar Catch (Left)
- (7) Safety Support / Bar Catch (Right)
- (8) Standard hook
- (9) Landmine (Place on inside or outside of machine)
- (10) Foot Plate
- (11) J Cup (left)
- (12) J Cup (Right)
- (13) Extension Chains (Set)
- (14) Stirrup Handles (Set)
- (15) T-Bar Row Handle
- (16) Olympic Bar Lock Plate
- (17) Steel Lock
- (18) Hook Welding
- (19) Tricep Rope
- (20) Jaw Lock Collar

WARRANTY

10 Years Parts, 1 Year Labor (Commercial)

TABLE OF CONTENTS

IMPORTANT SAFETY INSTRUCTIONS	4
ACCESSORIES LIST (INDIVIDUAL PACKAGING).....	5
PARTS LIST.....	8
BLISTER PACK SCREW LIST	9
ASSEMBLY STEPS.....	10

IMPORTANT SAFETY INSTRUCTIONS

WARRANTY



- Lifetime Parts and 1 Year Labor Warranty







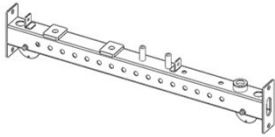
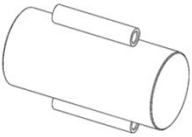
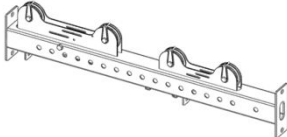
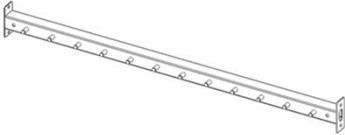
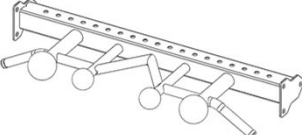
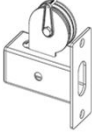
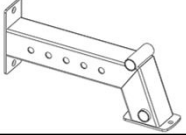
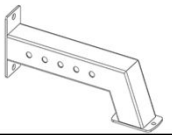
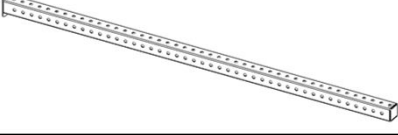
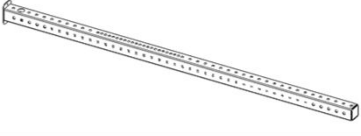
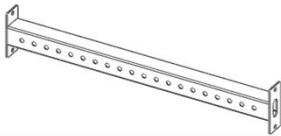
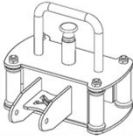
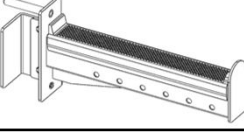
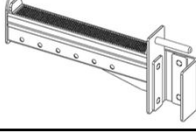

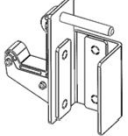
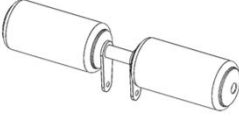
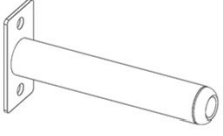
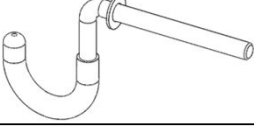
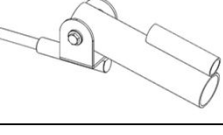
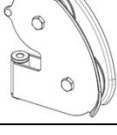
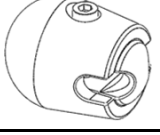
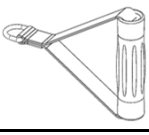
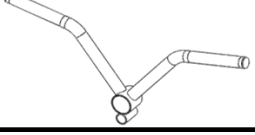

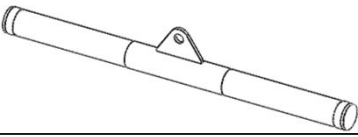
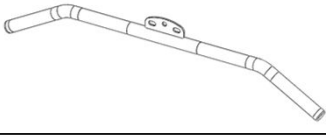
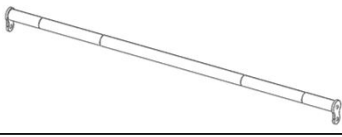
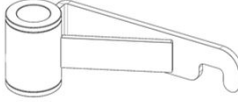
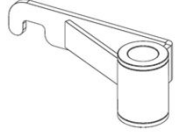

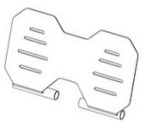
1.IMPORTANT SAFETY INSTRUCTIONS

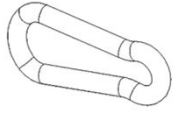
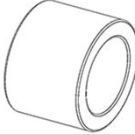
WARNING - Read all instructions before using this machine.

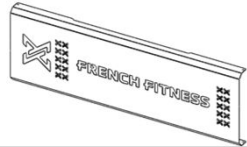
- Install the product on a flat level surface
 - Place your unit on a solid, level surface when in use
 - Never allow children on or near the machine.
 - Keep hands away from all moving parts.
 - Never drop or insert any object into any openings.
 - Care must be taken when lifting or moving the equipment so as not to injure your back. Always use proper lifting techniques and/or seek assistance if necessary.
 - Keep children and pets away from the machine at all times. DO NOT leave children unattended in the same room with the machine.
 - Only 1 person at a time should use the machine.
 - If the user experiences dizziness, nausea, chest pain, or any other abnormal symptoms, STOP the workout at once. CONSULT A PHYSICIAN IMMEDIATELY
 - Do not use the machine near water or outdoors.
 - Keep hands away from all moving parts.
 - Always wear appropriate workout clothing when exercising. DO NOT wear robes or other clothing that could become caught in the machine. Running or aerobic shoes are also required when using the machine.
 - Use the machine only for its intended use as described in this manual. DO NOT use attachments not recommended by the manufacturer.
 - Do not place any sharp objects around the machine.
 - Disabled person should not use the machine without a qualified person or physician in attendance.
-
- Never operate the machine if the machine is not functioning properly.
 - A spotter is recommended during exercise.

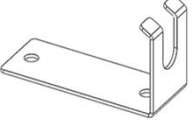
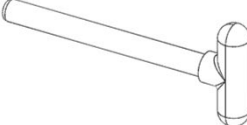
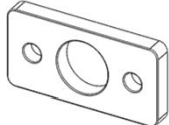
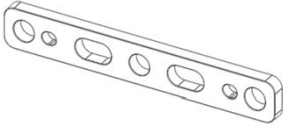
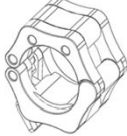
ACCESSORIES LIST (INDIVIDUAL PACKAGING)

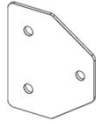
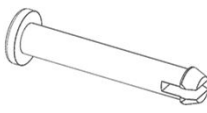
		
1	2	3
		
4	5	6
		
7	8	9
		
10	11	12
		
13	14	15
		
16	17	18
		
19	20	21
		
22	23	24

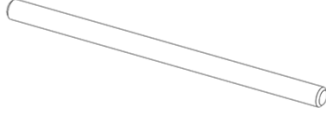
		
25	26	27
		
28	29	30
		
31	32	33
		
34	35	36
		
37	38	39
		
40	41	42
		
43	44	45
		
46	47	48

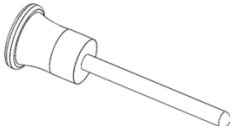
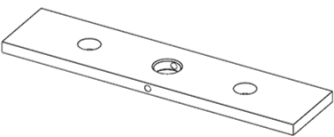
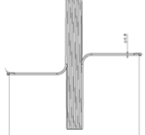
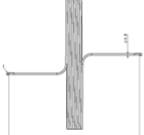
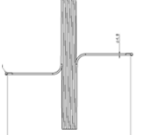

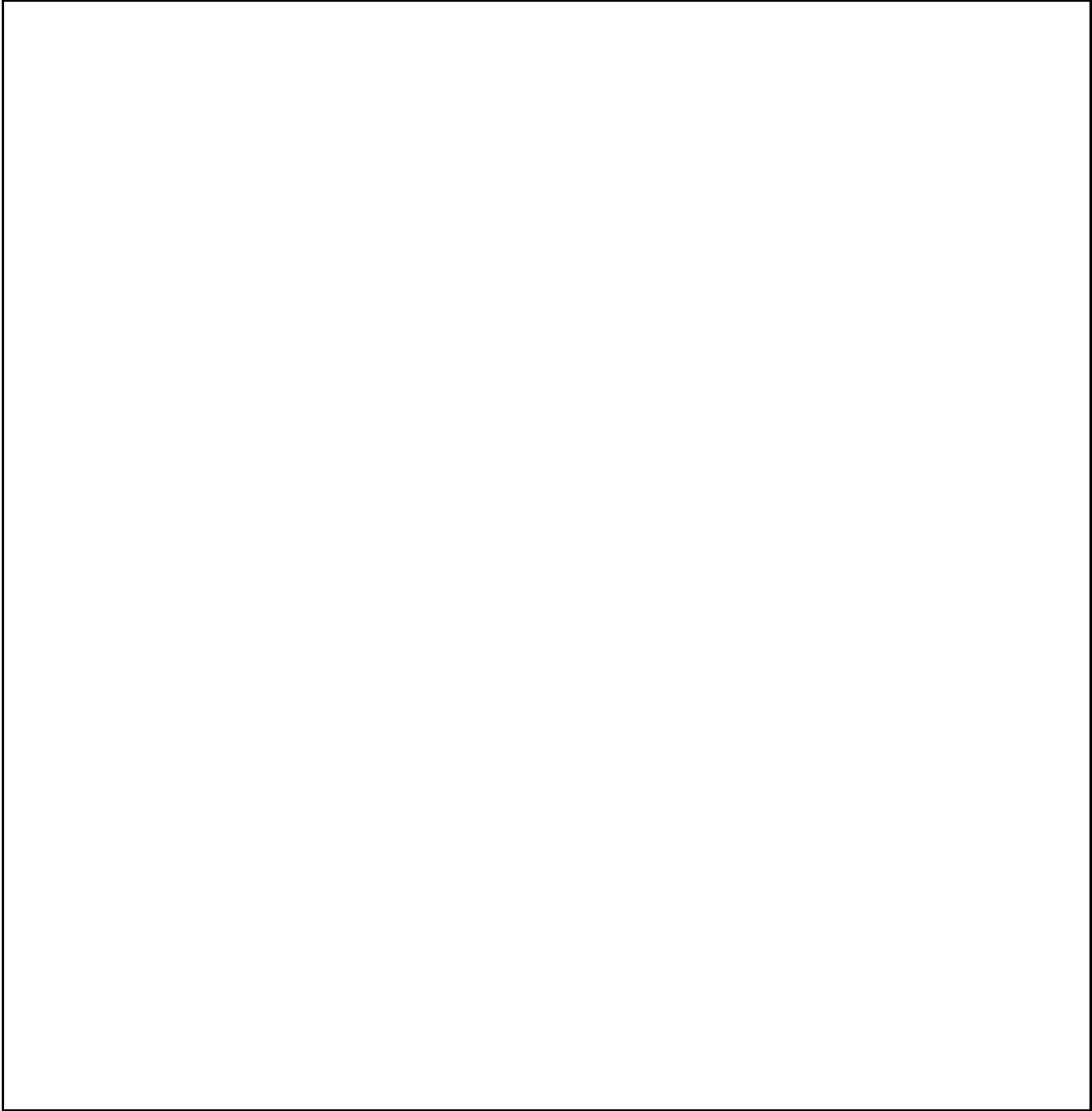





		
49	50	51
		
52	53	54

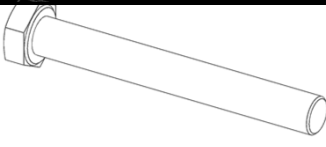
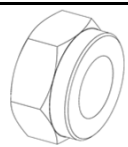

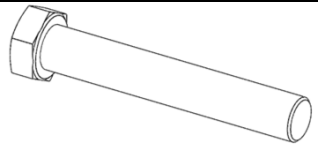
PARTS LIST

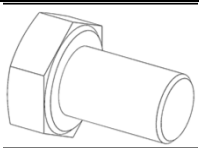
Model No.	Name	QTY
1	weight stack bottom tube welding assembly	2
2	weight stack assembly	2
3	top weight stack welding group	2
4	Hook column riser welding group	2
5	Front connection welding group	1
6	Upper pulley block	2
7	Front bend pipe welding group	1
8	Front bend pipe welding group	1
9	Rear riser welding group	2
10	Front pillar welding group	2
11	Lower connection welding group	2
12	Sliding sleeve welding group	2
13	Left safety frame group	1
14	Right safety frame group	1
15	Hook welding group left	1
16	Hook welding group right	1
17	Pressure leg welding group	1
18	Hanging rod welding group	6
19	Hook weldment	4
20	Bottom weight holder assembly	1
21	butterfly pulley block	2
22	cable head	2
23	low row bar	2
24	Pull welding group	1
25	Low row welding group	1
26	lat pulldown welding group	1
27	Push rod welding group	1
28	Smith Insurance Group left	1
29	Smith Insurance Group Right	1
30	Push rod assembly	1
31	Pedal set	1
32	Olympic bar 2.2m	2
33	safety hook	2
34	jacket	6
35	guide rod	4
36	Large guard plate	2
37	Smith optical axis	2
38	Olympic pole lock plate	2
39	T-shaped pin 100mm	1
40	Optical axis fixed seat	2
41	Optical axis fixing plate	2
42	barbell card holder	2
43	056 guide rod pad	4
44	Decorative board 2	8
45	Card rope pin (ABS)	4
46	Rubber mat	4
47	Pulley limit sleeve	8
48	φ25x430L fixed shaft	2
49	Top weight stack group	2
50	New pin	2
51	Long weight stack	38
53	Cable A (9890)	2
54	Cable B (2400)	2
55	Cable C (1900)	4

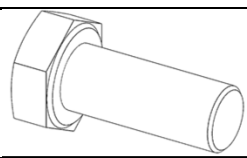
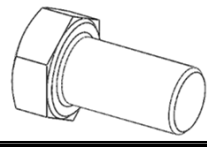
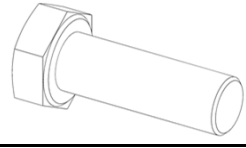
BLISTER PACK SCREW LIST

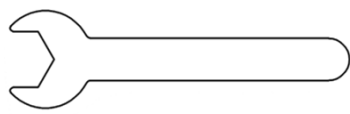
		
A	B	C
		
D	E	F
		
G	H	K
		
L	M	N
		
P		

Model No.	Name	QTY
A	External hexagonal screw M10X80	2
B	M10 lock nut	18
C	Flat washer Φ16	62
D	External hexagonal screw M16X100	58
E	Lock nut M16	58
F	External hexagonal screw M10X16	9
G	Φ10 flat washer	12
H	Small hole big pad Φ30XΦ11X2	1
K	External hexagonal screw M10X25	2
L	Hexagonal bolt M16×30	4
M	External hexagonal screws (galvanized) M10X30	10
N	No. 17 wrench	2
P	No. 24 wrench	2

ASSEMBLY STEPS

Steps	Model No.	Name	QTY
1	1	weight stack bottom tube welding assembly	1
	7	Front bend pipe welding group	1
	9	Rear riser welding group	1
	10	Front pillar welding group	1
	C	Flat washer $\Phi 16$	4
	D	External hexagonal screw M16X100	4
	E	Lock nut M16	4

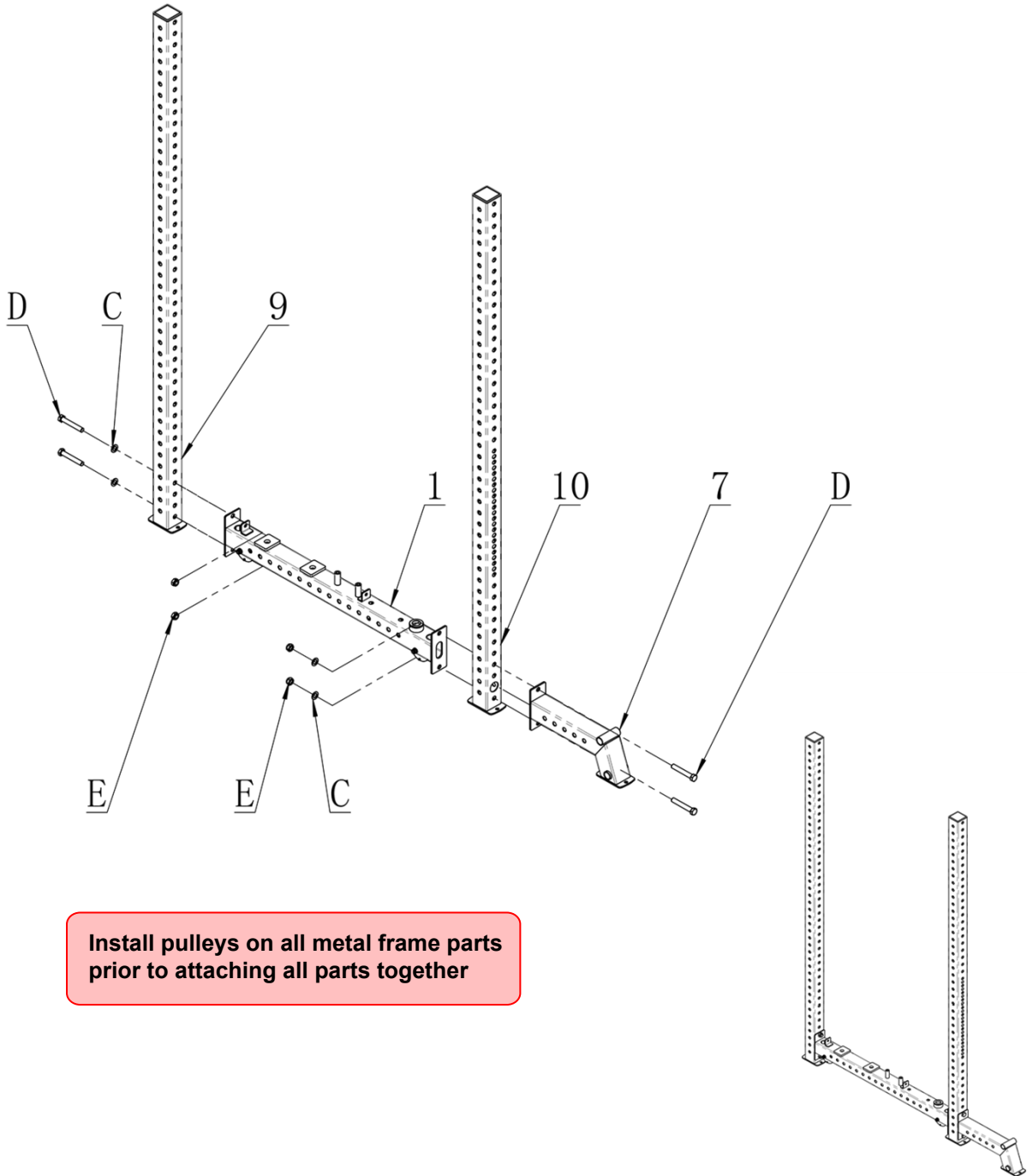

Install pulleys on all metal frame parts prior to attaching all parts together

Steps	Model No.	Name	QTY
2	1	weight stack bottom tube welding assembly	1
	8	Front bend pipe welding group	1
	9	Rear riser welding group	1
	10	Front pillar welding group	1
	C	Flat washer $\Phi 16$	4
	D	External hexagonal screw M16X100	4
	E	Lock nut M16	4

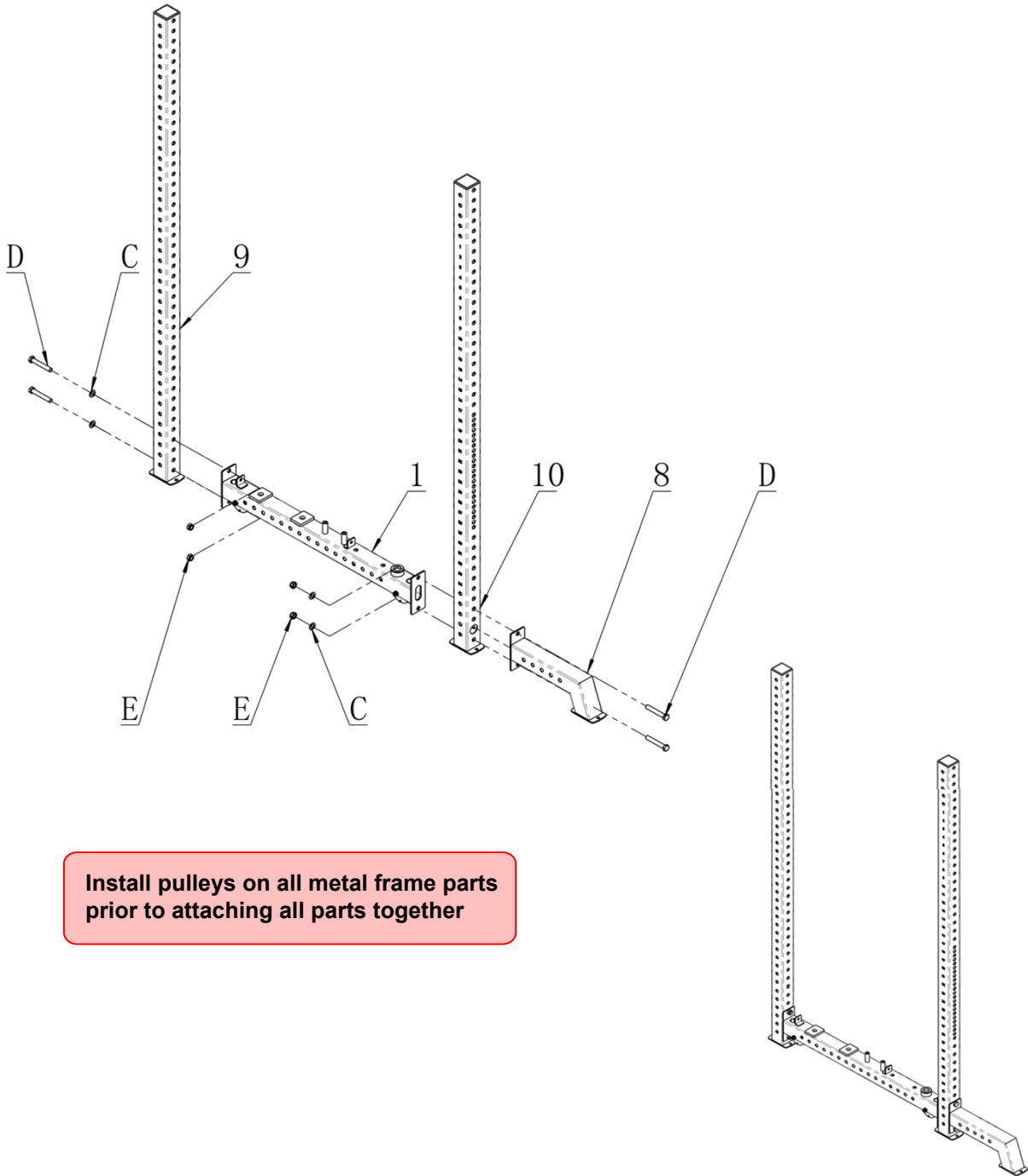

Steps	Model No.	Name	QTY
3	11	Lower connection welding group	2
	12	Sliding sleeve welding group	2
	C	Flat washer $\Phi 16$	8
	D	External hexagonal screw M16X100	8
	E	Lock nut M16	8

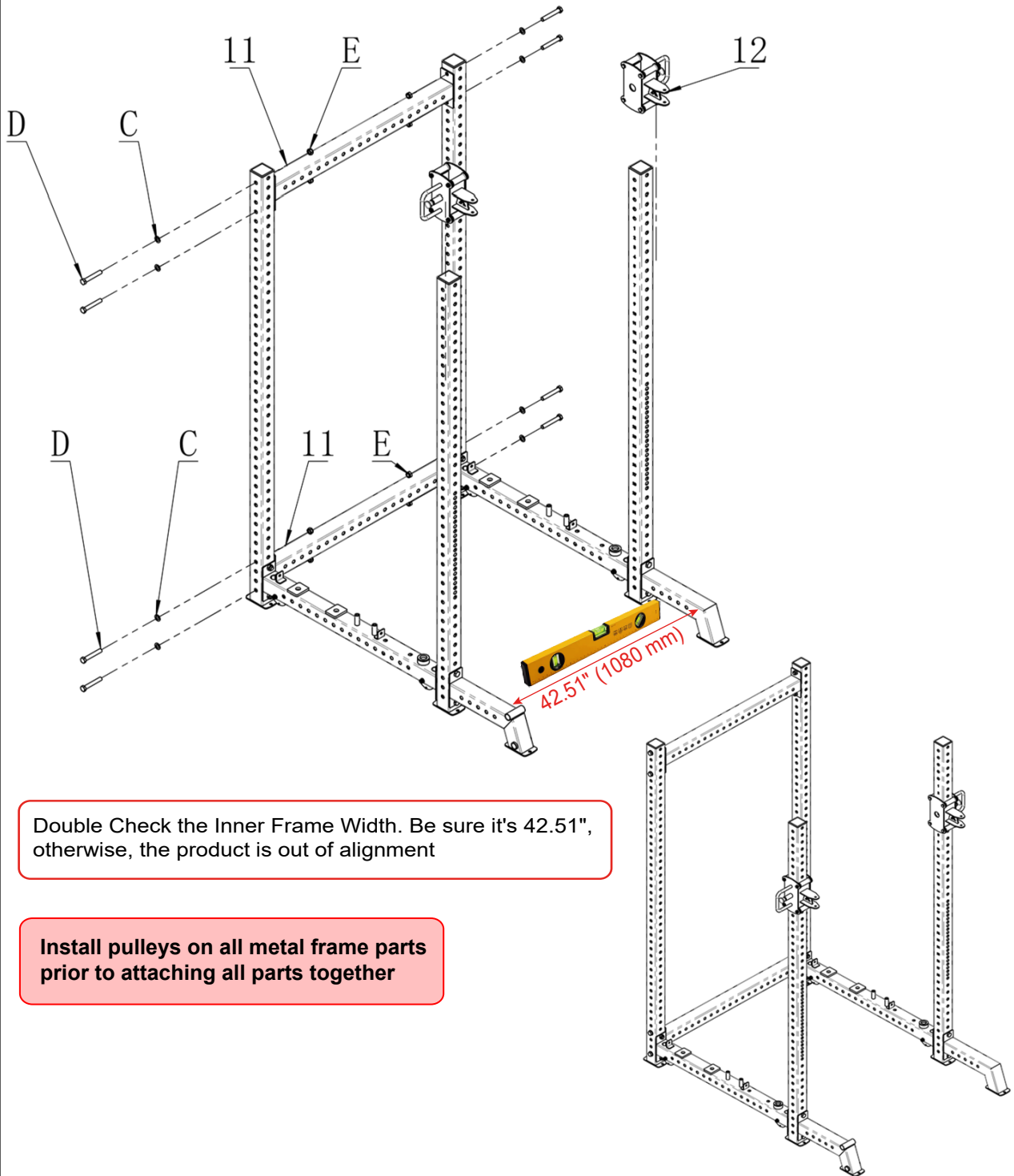

WARNING

Please DO NOT proceed with assembly if the floor is not level or the frame doesn't measure as described on page 12.

If the inner frame width does not measure 42.51" +/- 1/8" (as shown in the picture on page 12), please loosen frame bolts and push or pull the frame.

If the floor is not level (as shown in the picture on page 12), then the options are:

- placement elsewhere
- turning the machine at a different angle
- raising the proper area on the floor so the feet sit level with the rest if the feet (use a leveler on the smith bar in this case)

**FAILURE TO DO THIS WILL RESULT IN DISTORTION
OF THE SMITH MACHINE CAUSING IT
TO NOT GLIDE PROPERLY**

Steps	Model No.	Name	QTY
4	3	top weight sack welding group	2
	6	Upper pulley block	2
	38	Olympic pole lock plate	2
	C	Flat washer $\Phi 16$	8
	D	External hexagonal screw M16X100	8
	E	Lock nut M16	8

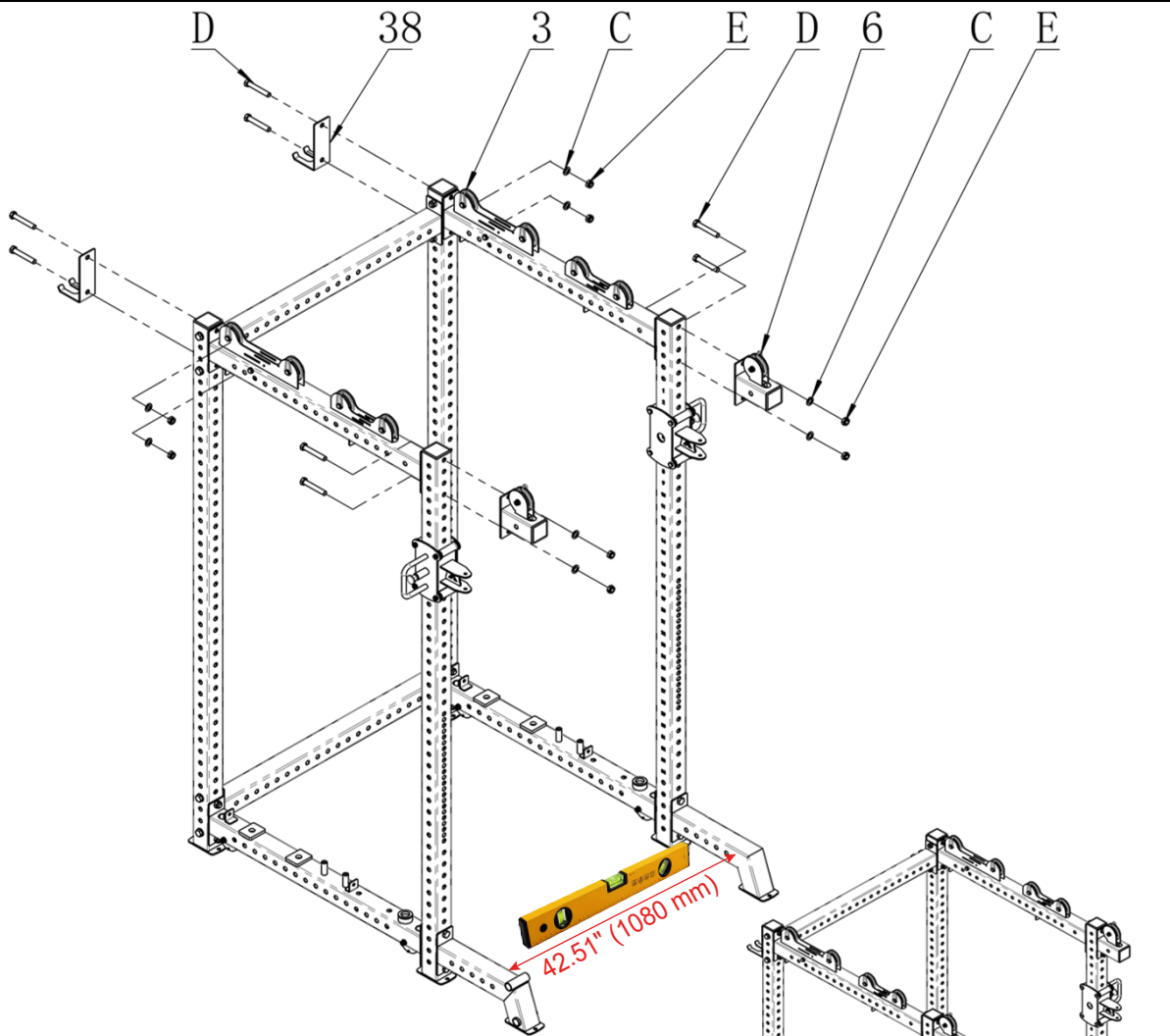

Double Check the Inner Frame Width. Be sure it's 42.51", otherwise, the product is out of alignment

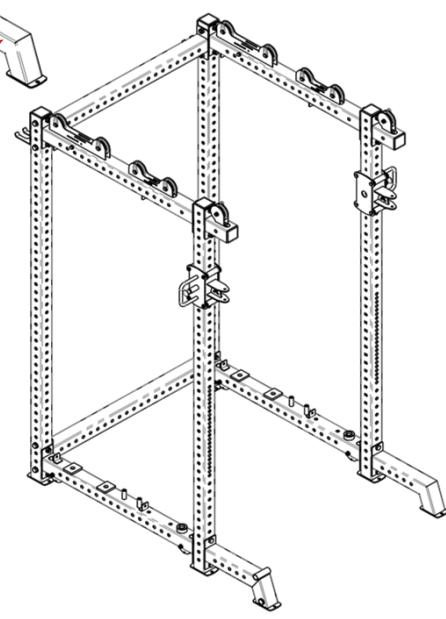

Steps	Model No.	Name	QTY
5	4	Hook column riser welding group	2
	C	Flat washer $\Phi 16$	8
	D	External hexagonal screw M16X100	4
	E	Lock nut M16	4
	L	Hexagonal bolt M16x30	4

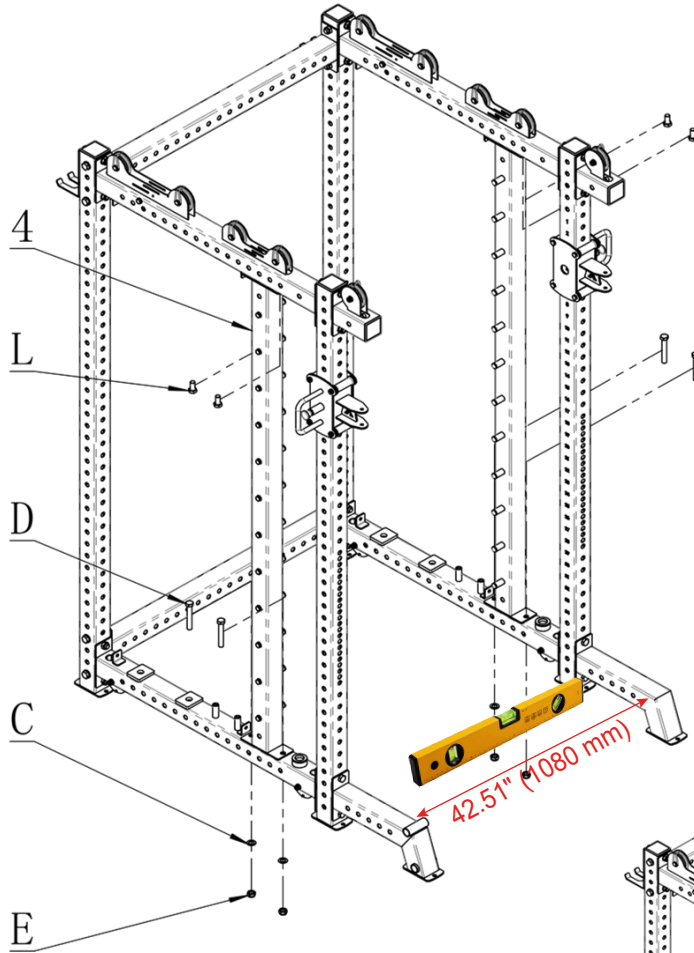

Double Check the Inner Frame Width. Be sure it's 42.51", otherwise, the product is out of alignment

Install pulleys on all metal frame parts prior to attaching all parts together

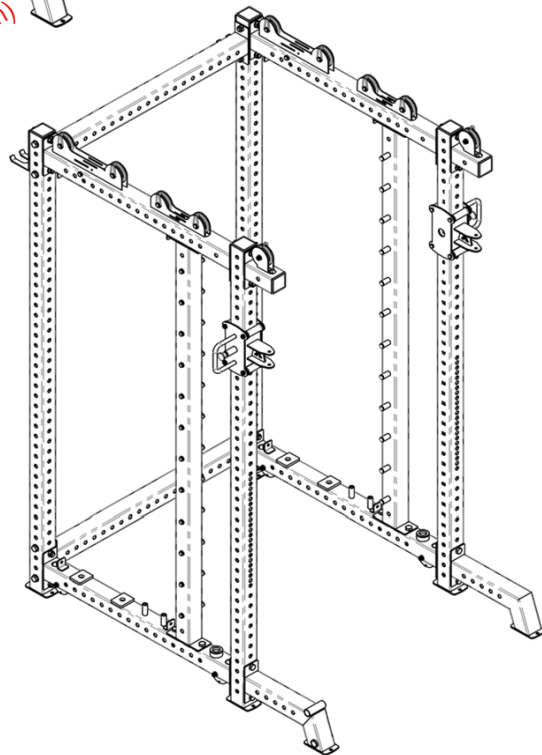

Steps	Model No.	Name	QTY
6	44	Decorative board 2	8
	C	Flat washer $\Phi 16$	12
	D	External hexagonal screw M16X100	12
	E	Lock nut M16	12

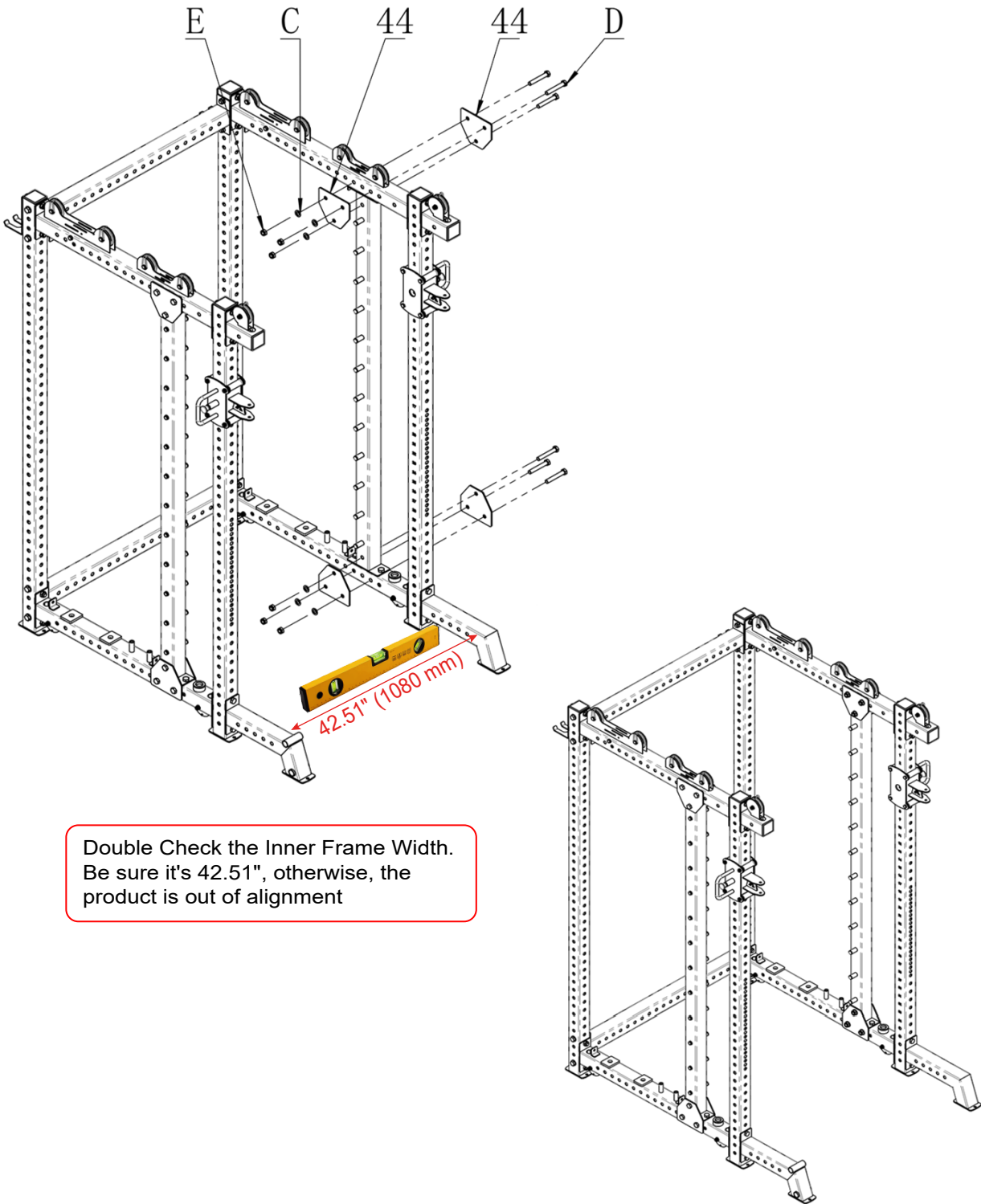

Double Check the Inner Frame Width.
Be sure it's 42.51", otherwise, the
product is out of alignment

Steps	Model No.	Name	QTY
7	28	Smith Insurance Group left	1
	29	Smith Insurance Group right	1
	30	Push rod assembly	1
	37	Smith optical axis	2
	43	056 guide rod pad	4

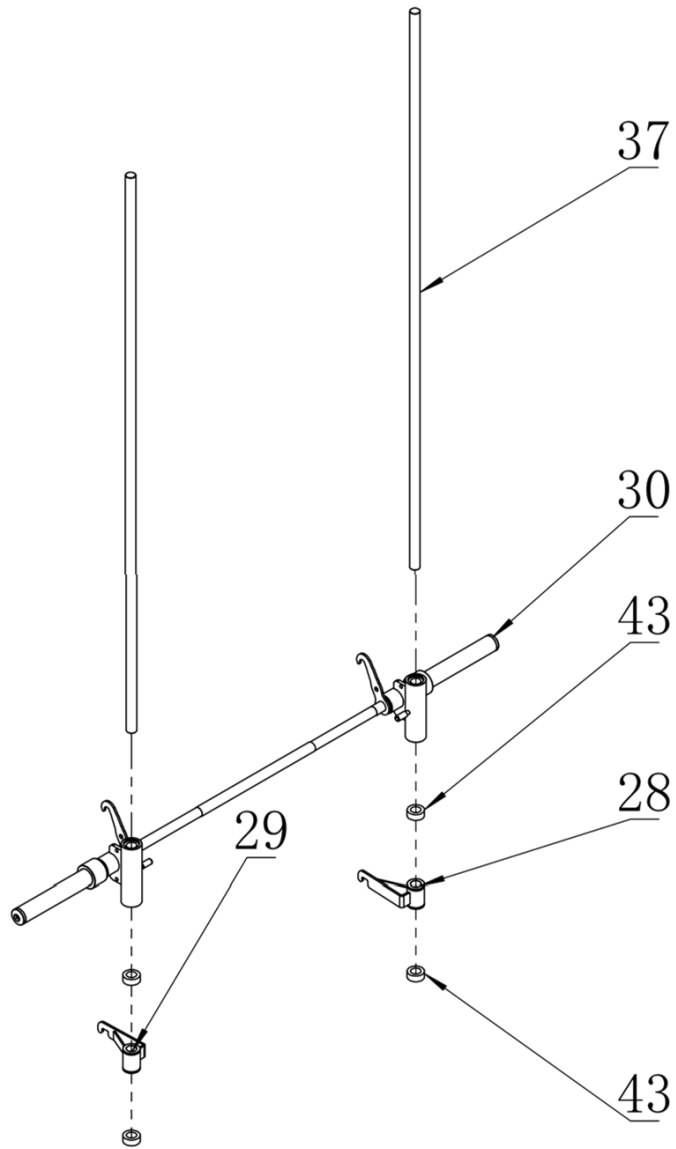

Steps	Model No.	Name	QTY
8	40	optical axis holder	2
	M	External hexagonal screw M10X30	4

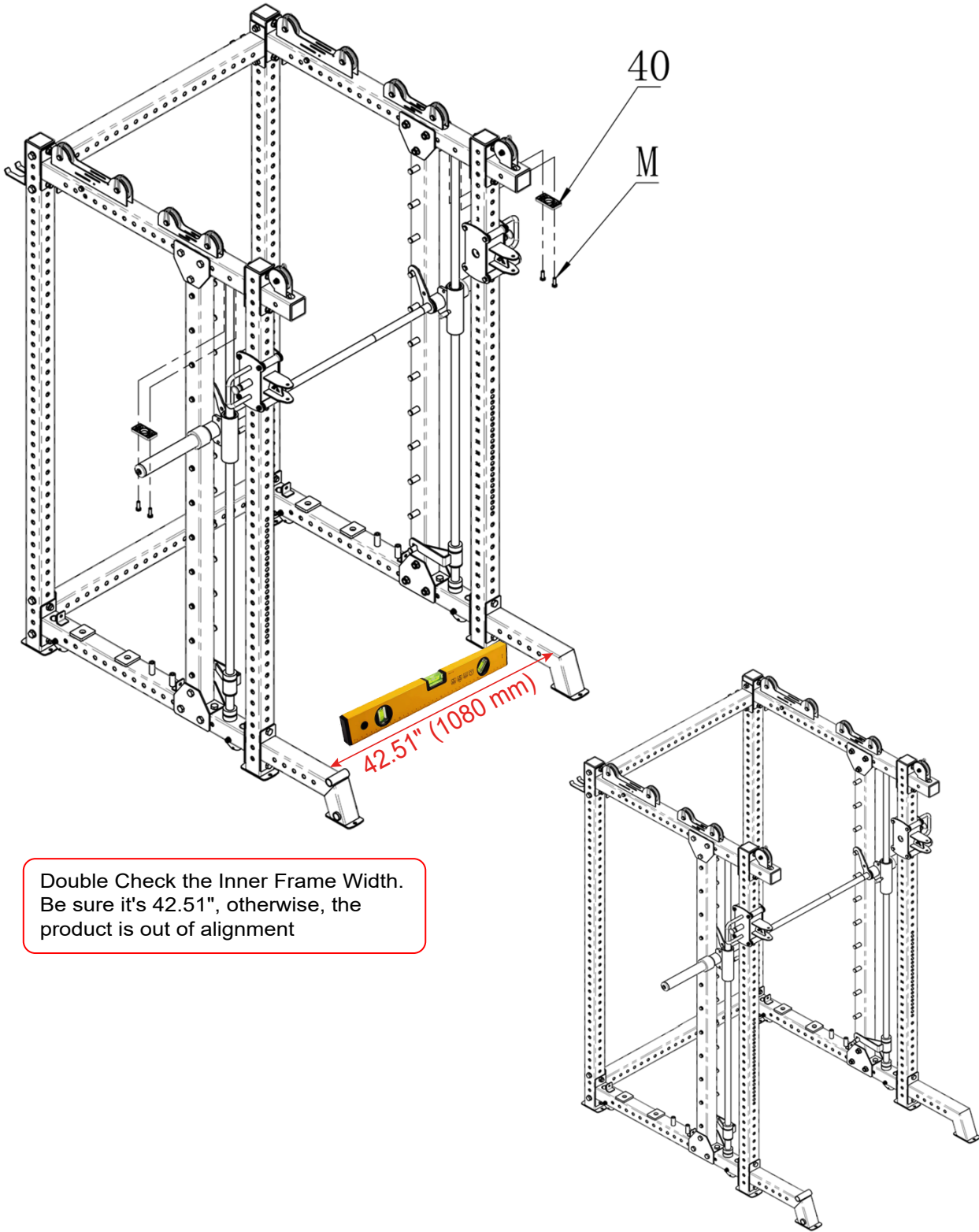

Steps	Model No.	Name	QTY
9	5	Front connection welding group	1
	C	Flat washer $\Phi 16$	6
	D	External hexagonal screw M16X100	6
	E	Lock nut M16	6

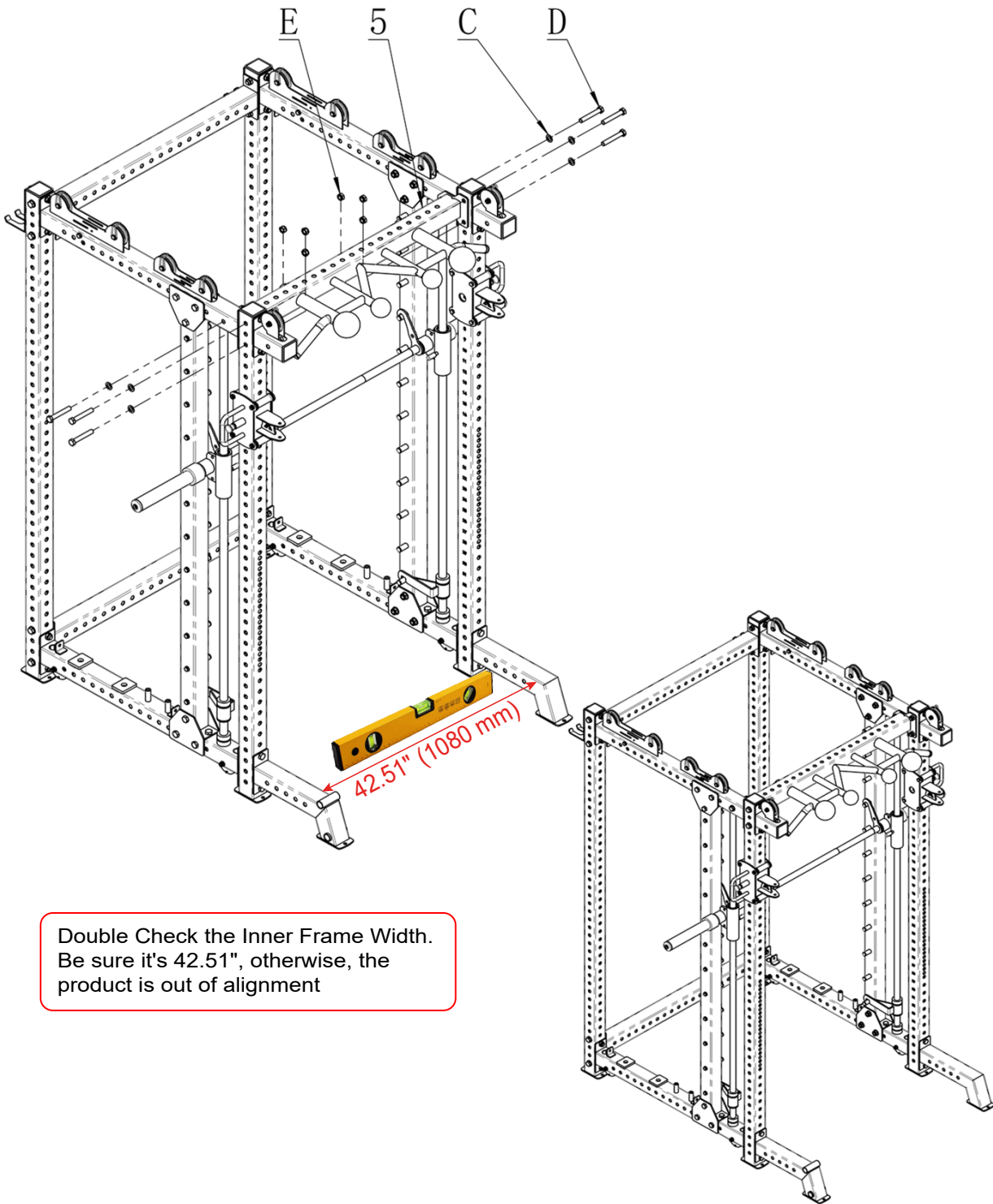

Double Check the Inner Frame Width. Be sure it's 42.51", otherwise, the product is out of alignment

Steps	Model No.	Name	QTY
10	35	guide rod	4
	41	Optical axis fixing plate	2
	46	rubber pad	4
	49	Top weight stack group	2
	51	weight stack	38
	M	External hexagonal screw M10X30	4

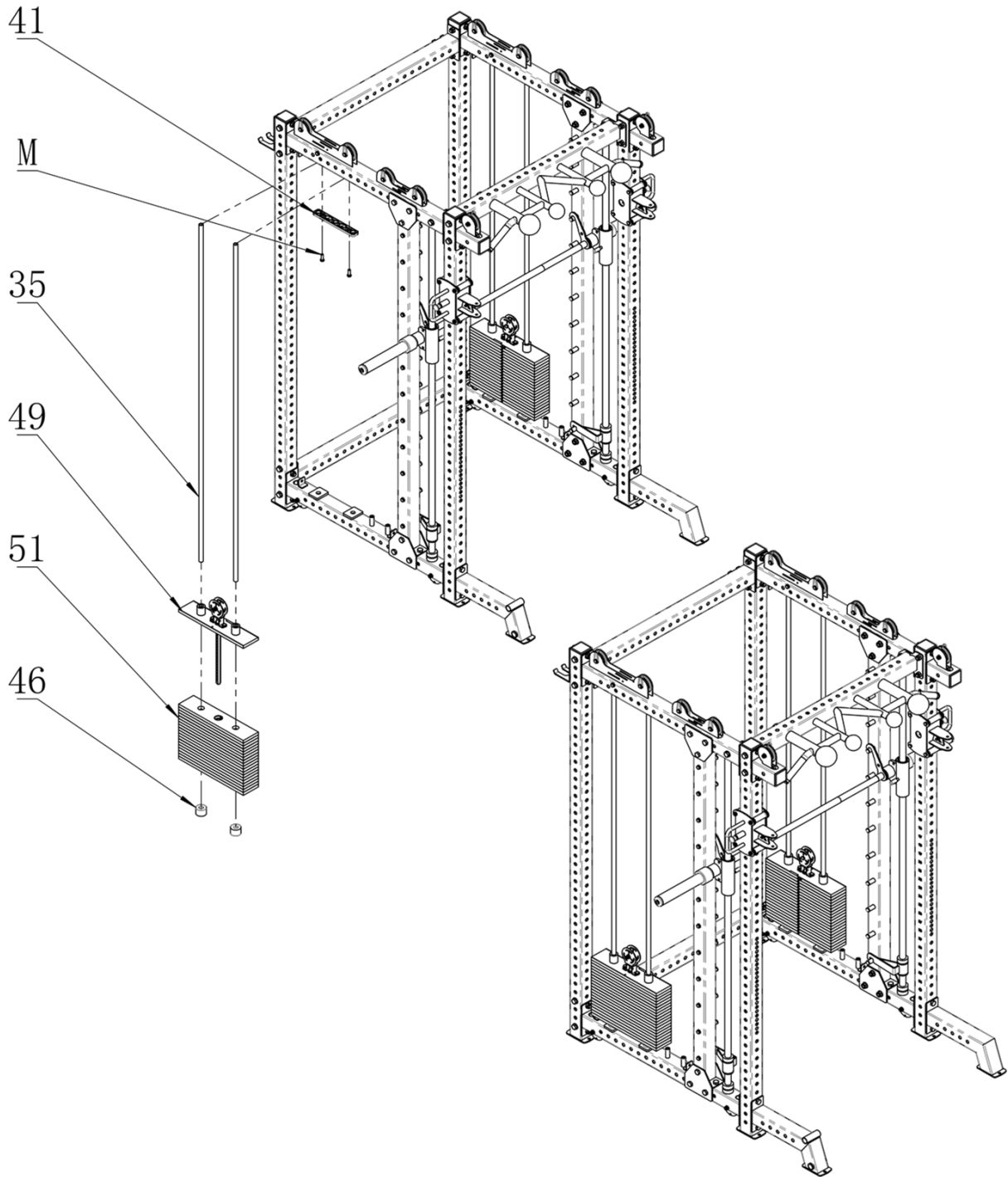

Steps	Model No.	Name	QTY
11	19	Hook weldment	4
	21	butterfly pulley block	2
	47	Pulley limit sleeve	8
	50	New pin	2
	A	External hexagonal screw M10X80	2
	B	M10 lock nut	6

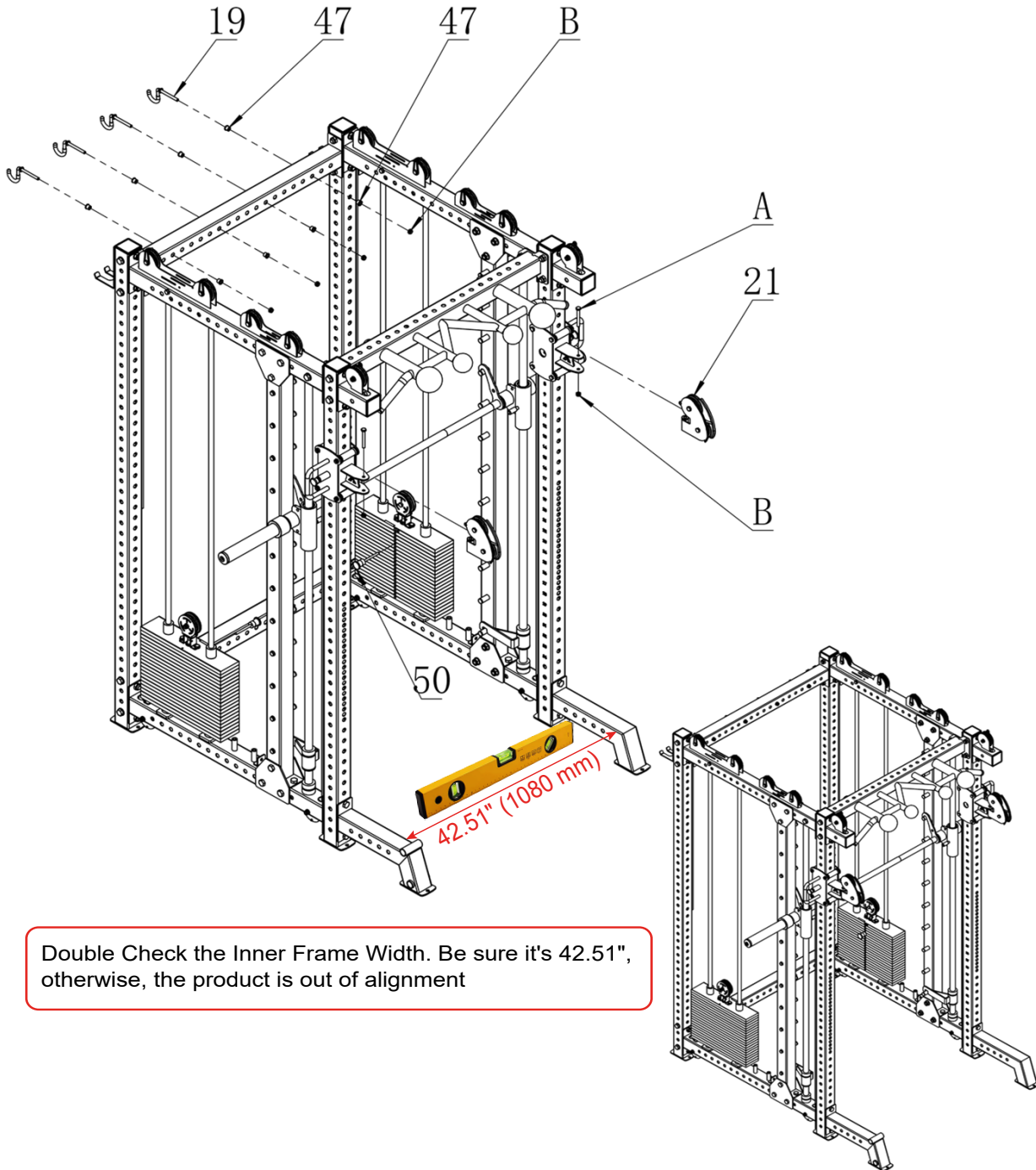

Double Check the Inner Frame Width. Be sure it's 42.51", otherwise, the product is out of alignment

Steps	Model No.	Name	QTY
12	22	cable head	2
	23	low row bar	2
	33	safety hook	2
	45	Card rope pin (ABS)	4
	53	cable A(9890)	2
	B	M10 lock nut	2
	G	Φ10 flat washer	2
	K	External hexagonal screw M10X25	2

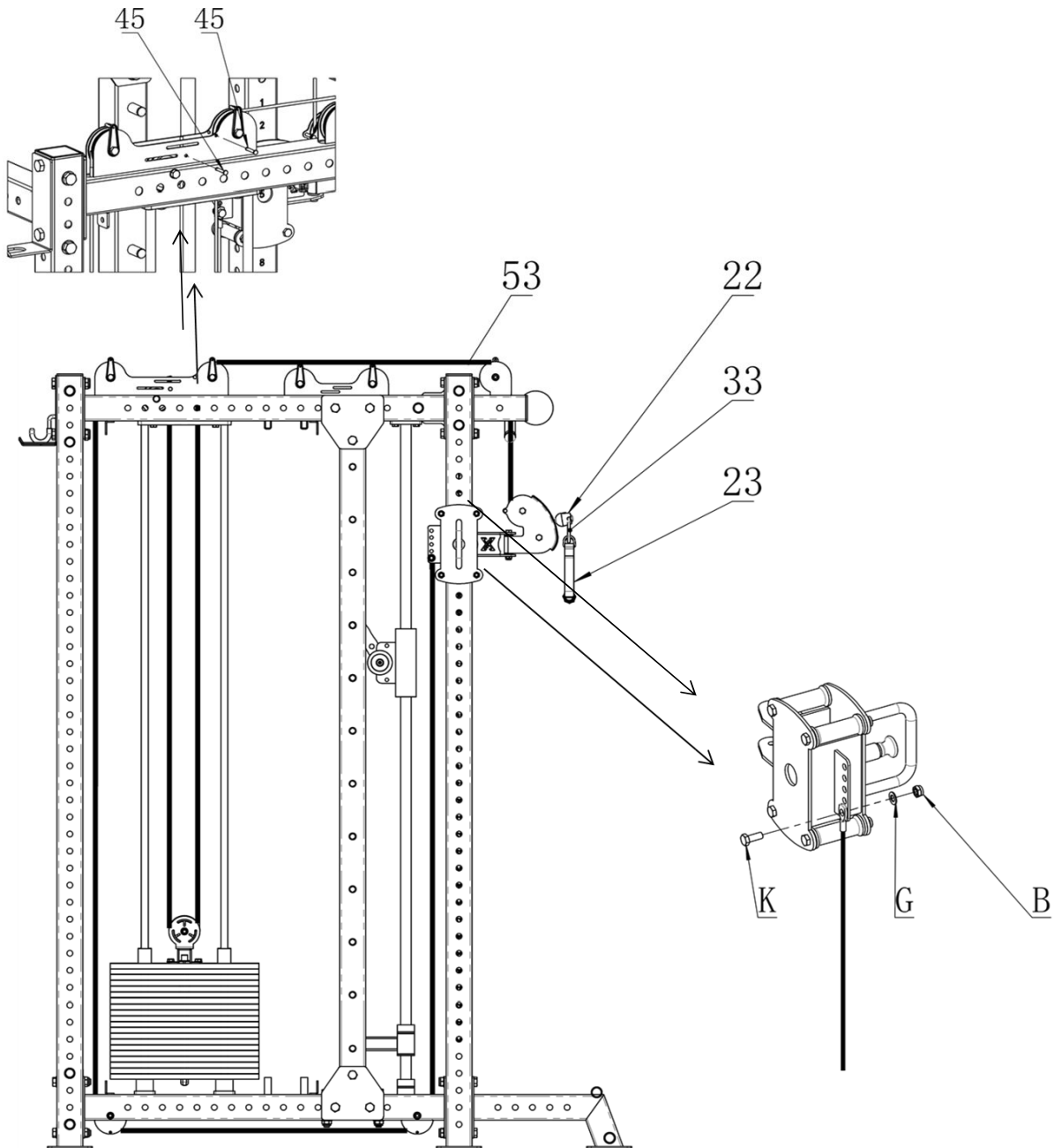

Cable routing diagram

Steps	Model No.	Name	QTY
13	2	Weight stack assembly	2
	54	cablc B (2400)	2
	55	cablc C (1900)	4
	B	M10 lock nut	2
	G	Φ10 flat washer	2
	M	External hexagonal screws (galvanized) M10X30	2

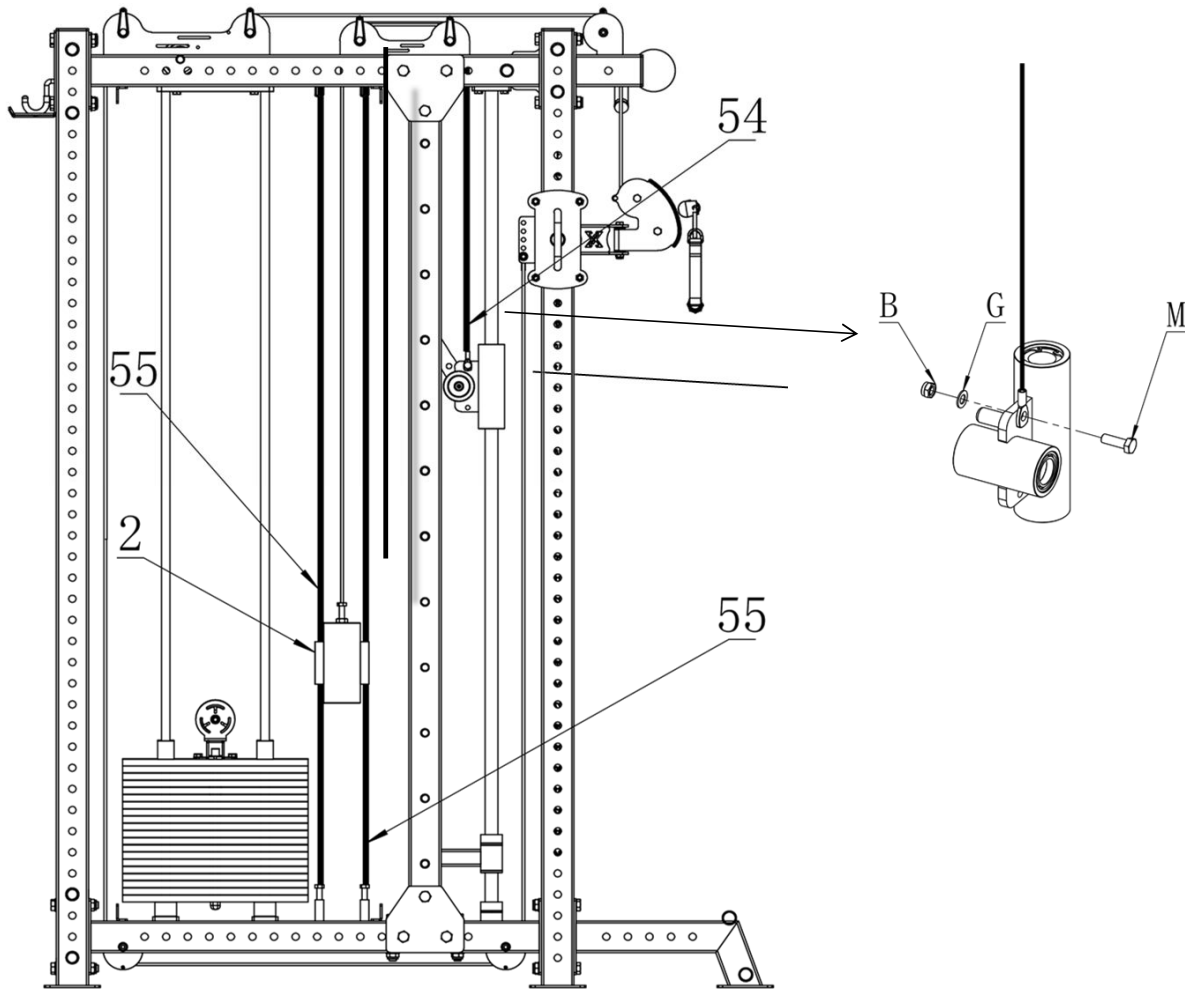

Cable routing diagram

Steps	Model No.	Name	QTY
14	18	Hanging rod welding group	6
	34	9107-0609	6
	42	barbell card holder	2
	C	Flat washer $\Phi 16$	12
	D	External hexagonal screw M16X100	12
	E	Lock nut M16	12

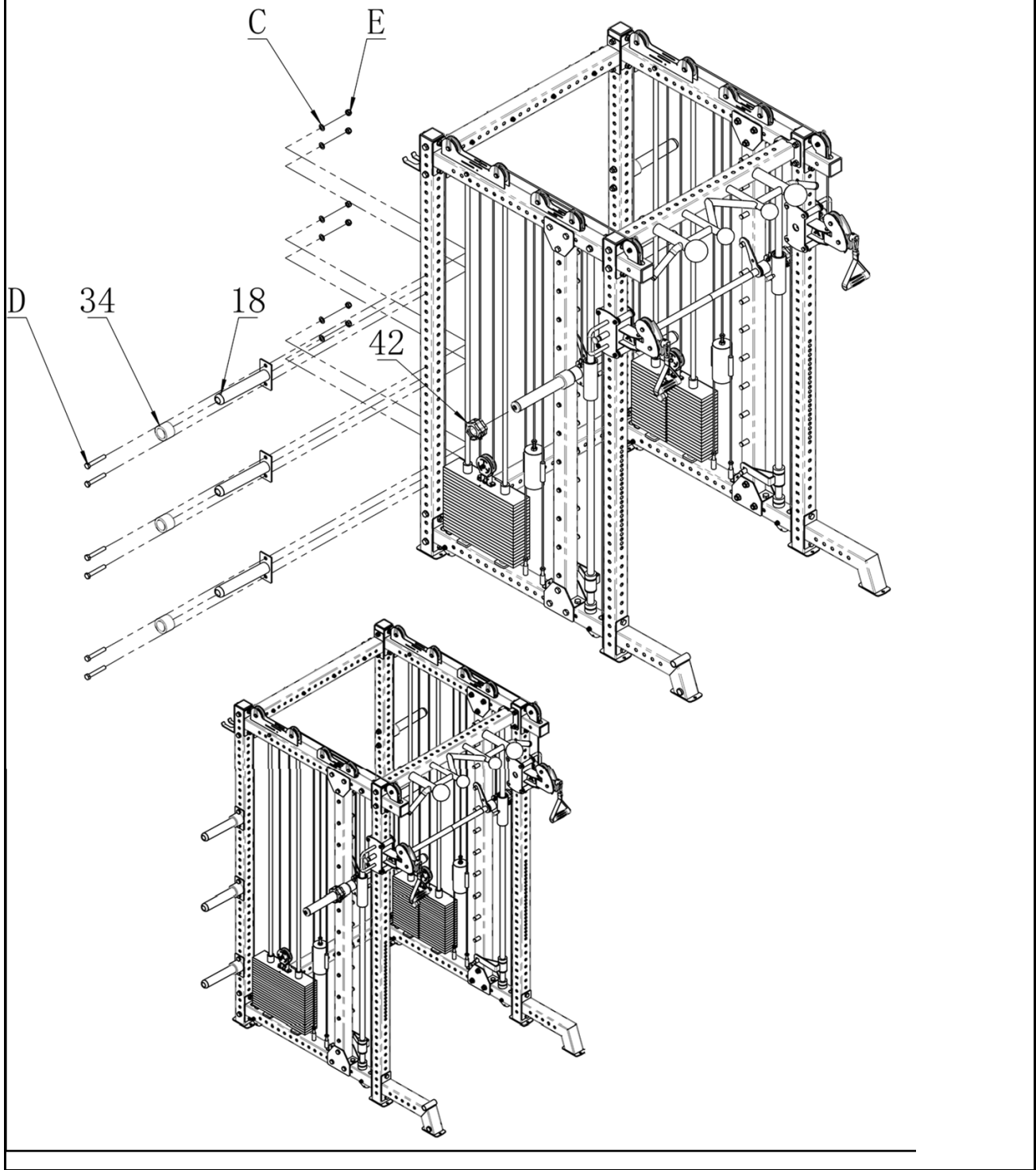

Steps	Model No.	Name	QTY
15	36	Large guard plate	2
	B	M10 lock nut	8
	F	External hexagonal screw M10X16	8
	G	Φ10 flat washer	8

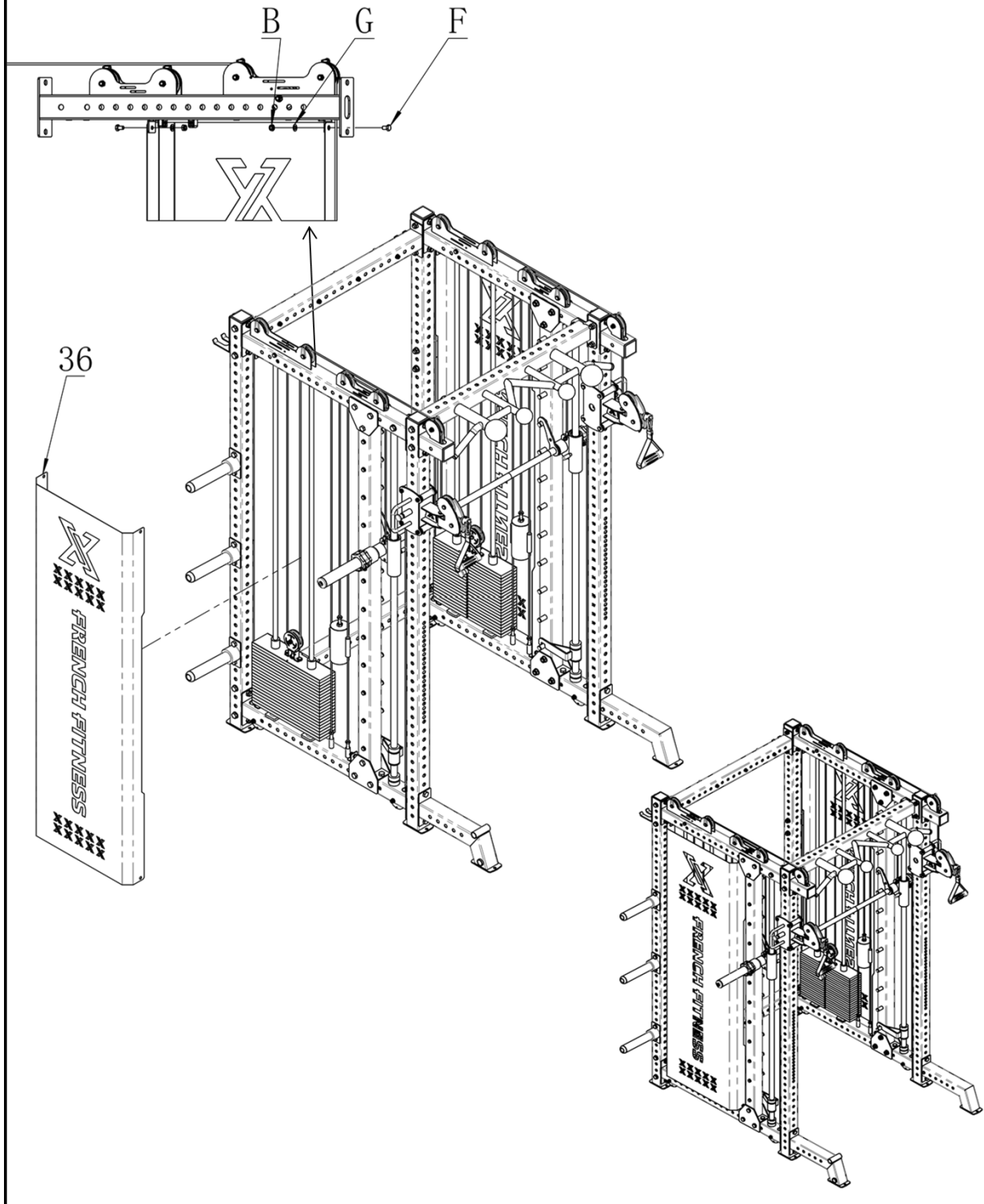

Steps	Model No.	Name	QTY
16	20	Bottom weight holder assmely	1
	31	Pedal set	1
	48	φ25x430L fixed shaft	2
	F	External hexagonal screw M10X16	1
	H	Small hole big pad Φ30XΦ11X2	1

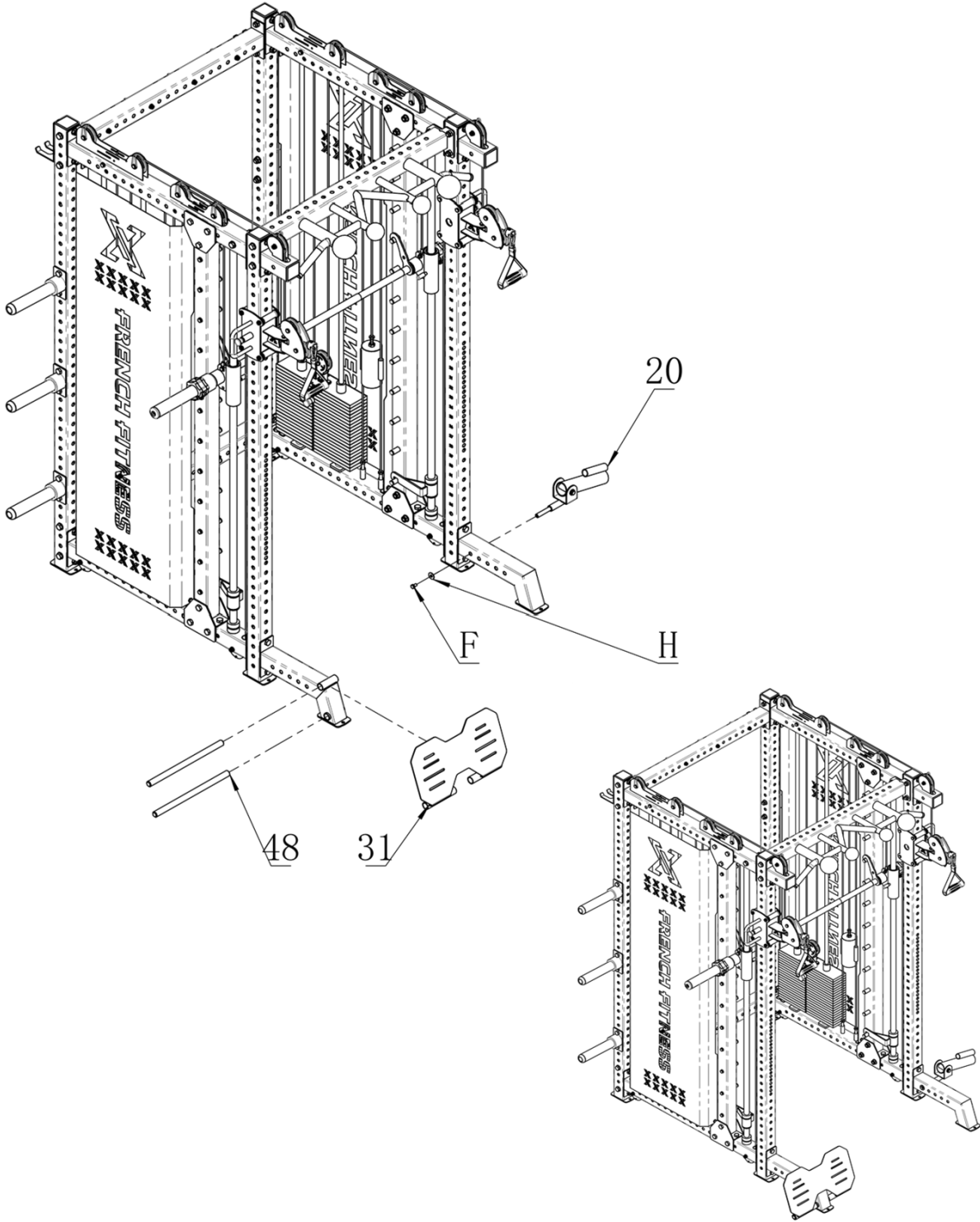

Steps	Model No.	Name	QTY
17	13	Left safety frame group	1
	14	Right safety frame group	1
	15	Hook welding group left	1
	16	Hook welding group right	1

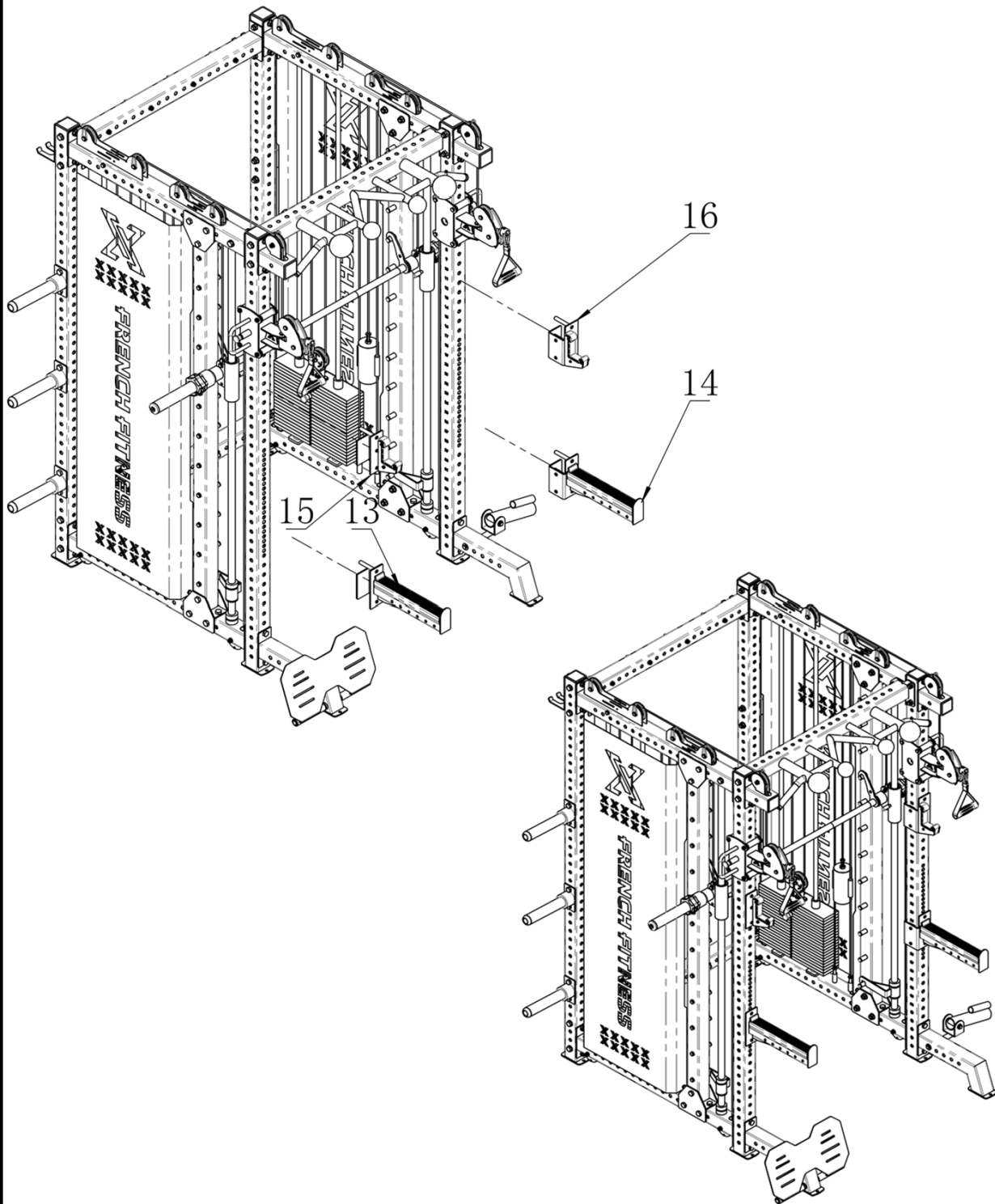

Steps	Model No.	Name	QTY
18	17	Pressure leg welding group	1
	32	Olympic bar 2.2m	2
	39	T-shaped pin 100mm	1

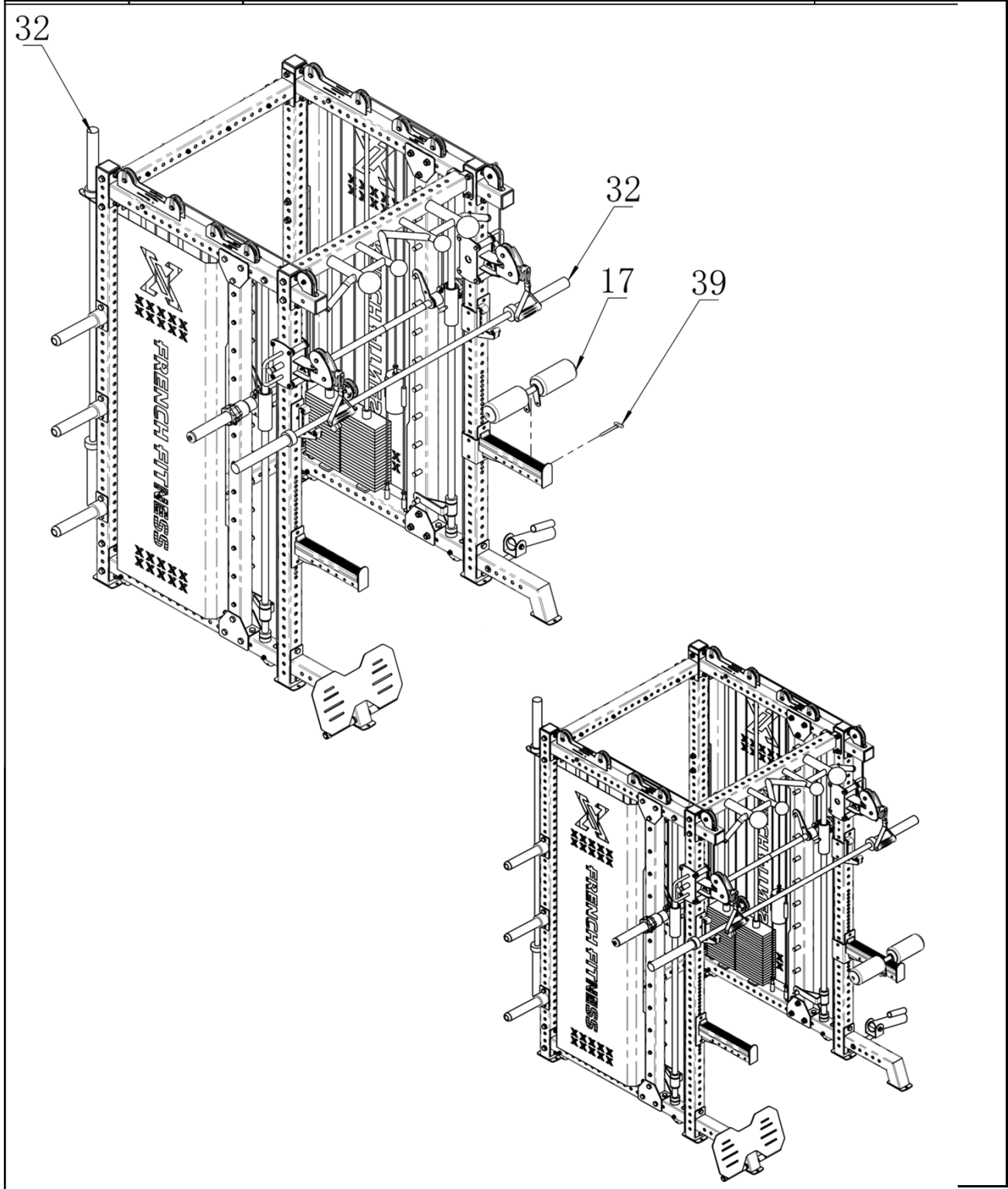

Steps	Model No.	Name	QTY
19	24	Pull welding group	1
	25	low row welding group	1
	26	lat pulldown welding group	1
	27	Push rod welding group	1

